



## Moving Interiors

# Cargo Floor Lift

Manually Operated

Accuride is a Development Partner and Tier2 Supplier of Automotive Sliding Systems

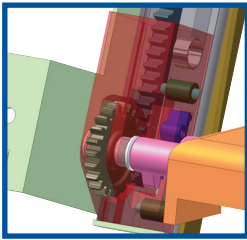

- Locks into position for stability
- Multiple height positions
- 75–150 kg. load rating

### CARGO FLOOR LIFT

Accuride's Cargo Floor Lift is a multi-position, manually operated slide mechanism designed to be integrated with vehicle platforms to expand and upgrade storage options in automotive applications. The slide mechanism locks into place at multiple height locations, allowing cargo to be stowed on or beneath the platform. In addition, installations below the basic level of the compartment create space for the stowage of taller items. Height adjustment is easily activated through a simple pivot action making the cargo area more versatile.

### Features & Benefits

- Multiple height positions provide a variety of storage and load options.
- Locking feature - keeps shelf securely in position.
- Intuitive height adjustment – lock is released when the shelf is pivoted.
- Central handle facilitates one-handed operation.
- Rack and pinion construction synchronizes slides to provide smooth movement and prevent racking.
- Constant force spring assists in lifting of the shelf and ensures consistent slide performance.
- If accidentally released the unit shelf locks in the nearest lower position.

### Intuitive Self Positioning System

To lift floor, pivot to 20° (to unlock) and pull upwards.

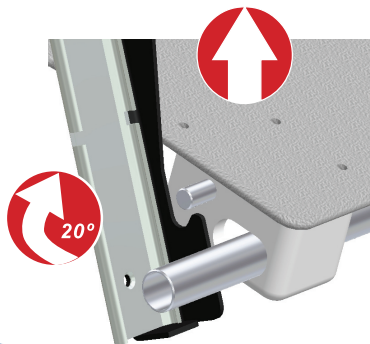

Guide Bracket

To lower floor, pivot to 20° (to unlock) and push downwards.

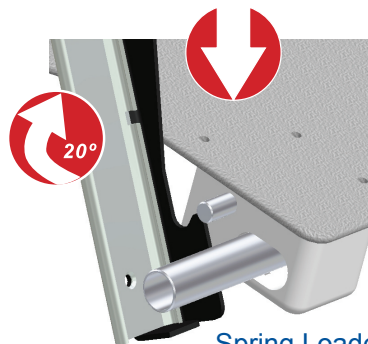

Spring Loaded Pivot

When floor is dropped, guide bracket stops floor at next lowest position allowing system to lock.

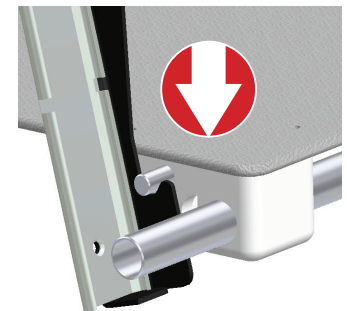

For more information or to discuss your project requirements call 562-903-0490

**Accuride**  
www.accuride.com

\*This product is covered by U.S. and various foreign patents issued and or pending.