

Accuride®

3600-200/3600-201 QUICK REFERENCE

MODEL 3600-200
with 32 mm System Holes

MODEL 3600-201
StowAway Slide
Bracket Mount, Self-Closing
175 lbs.* [80 kg.] Capacity

APPLICATIONS: Use in kitchen and utility rooms for trash can pull-outs, storage shelves, and pantries. **This product is covered by U.S. (6,145,945) and various foreign patents issued and/or pending.**

Total Side Space for 200: .83" x 2 with bracket
Total Side Space for 201: 1.59" x 2
Length: 22"
Slide Dimensions for 200: 1.52" x 2.15"
Slide Dimensions for 201: 2.28" x 2.20"
Load Rating: 175 lbs.

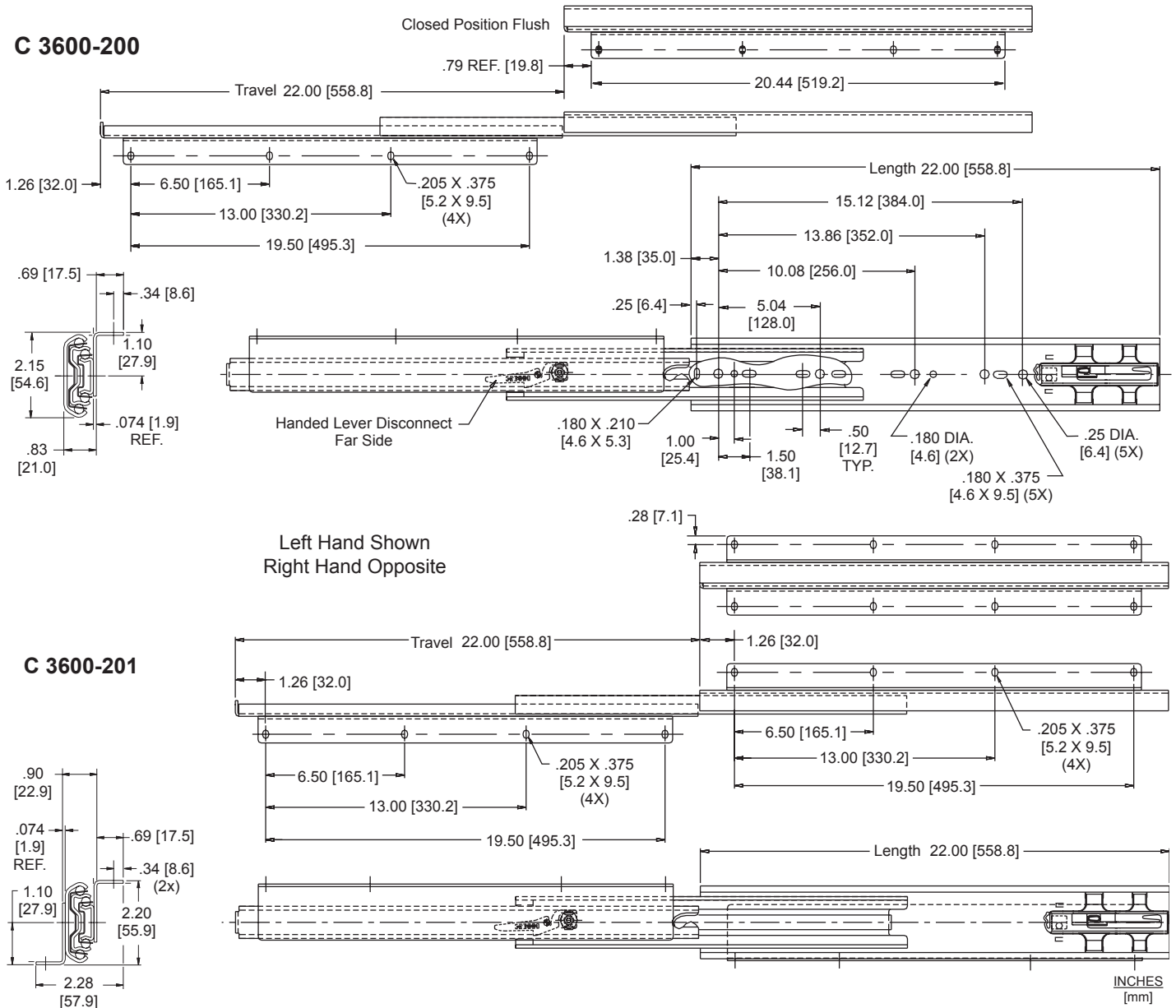

Finish	Bright electro-zinc (C) plating only
Length	22" [559 mm] only
Travel	Full extension
Height	3600-200 with bracket: 2.15" [54.6 mm] 3600-201 with brackets: 2.20" [55.9 mm]
Side Space	3600-200 with bracket: .83" [21.0 mm] 3600-201 with brackets .90" [22.7 mm]
Load	175 lbs. [80 kg.] per pair*

Mounting	3600-200: Fixed inboard bracket 3600-201: Fixed inboard top bracket and fixed outboard bottom bracket
Hardware	Through slide: #8 truss head screw Through brackets: #10 pan head screws
Features	Handed slide. Self-close action eliminates bounce-back and drawer creep. Handed lever disconnect. Silencing open and closed.

* Load rating based on an 18" slide on a 42" wide drawer cycled 75,000 times.

Installation Instructions

Model 3600-200

Fixed Inboard Mounting Bracket

1. To ensure proper operation of the slide, make certain all mounting screws are inserted so the screw heads are inside the slides.

NOTE: Secure slides using all mounting holes on the slide and on the bracket.

2. With the slides fully extended, install slide outer members (largest) into cabinet using #8 screws (or 6 mm System screws, not provided by Accuride). Be sure slides are parallel.
3. With slides extended, center the platform and drive the #10 screws up through the moving member brackets into the bottom of the platform.
4. Adjust slide position until movement is smooth. Tighten all screws to complete installation.

Model 3600-201

Fixed Inboard Top Mounting Bracket and Fixed Outboard Bottom Mounting Bracket

1. Mark a line at least .34" [8.6 mm] in from the right side of the cabinet opening and parallel to the cabinet side.
2. Locate a point on this line 1.26" [32.0 mm] back from the desired front of the slide.
3. Using #10 screws, mount the cabinet member bracket through the first hole at this point.
4. Mount the left hand slide similarly, locating the screw center line of the cabinet member bracket at least .34" [8.6 mm] in from the left side of the opening.
5. Keeping the right and left hand slides parallel, install the remainder of the cabinet member screws.

NOTE: Secure slides using 4 screws per bracket.

NOTE: When using soft material such as particle board, replace the rear cabinet mounting screws with through bolts.

6. With slides extended, center the platform and drive the screws up through the moving member brackets into the bottom of the platform.

Slide Ordering Instructions

Complete your order for Accuride model 3600-200 or 3600-201 by specifying the following. Slides are handed. Ordered as pairs.

	4 Pair	C	3600-200	D
Total Slides Required	_____	_____	_____	_____
Slide Finish	_____	_____	_____	_____
Slide Model With Fixed Inboard Bracket	_____	_____	_____	_____
Optional Polybag Packaging	_____	_____	_____	_____

	4 Pair	C	3600-201	D
Total Slides Required	_____	_____	_____	_____
Slide Finish	_____	_____	_____	_____
Slide Model With Fixed Inboard Top Bracket and Fixed Outboard Bottom Bracket	_____	_____	_____	_____
Optional Polybag Packaging	_____	_____	_____	_____

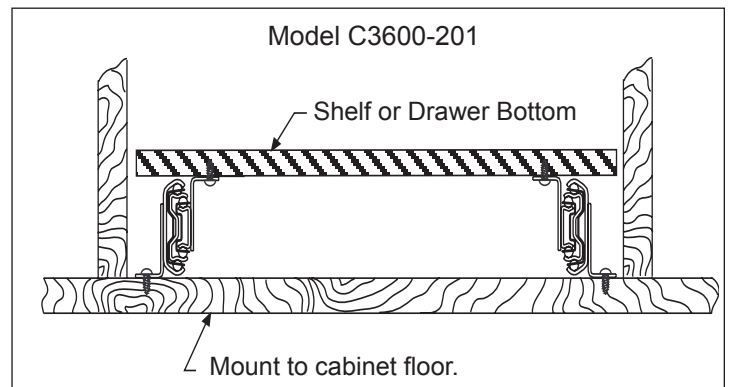
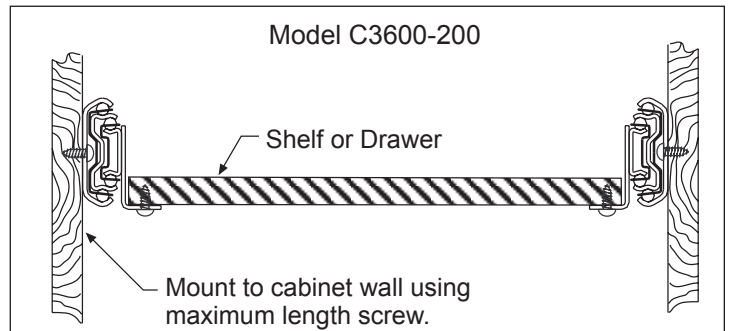
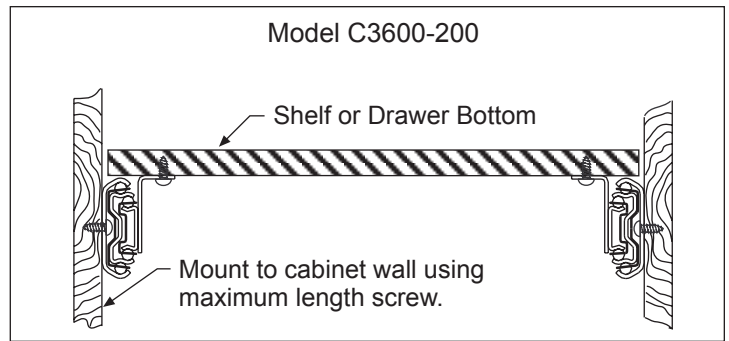

Packaging

Models C3600-200 and C3600-201 are available in distributor packaging only.

Distributor (D) Pack: Packaged 4 pair per box. Polybag includes 1 pair of slides packed with mounting screws.

Specifications

Slide members: Cold rolled steel

Ball retainers: Cold rolled steel

Ball bearings: Carburized steel

NOTE: Specifications, materials, prices, terms, and delivery are subject to change without notice.

Accuride

ACCURIDE INTERNATIONAL INC.

12311 Shoemaker Avenue
Santa Fe Springs, CA 90670

TEL (562) 903-0200

FAX (562) 903-0208

www accuride.com

Manufacturing, Engineering, and Sales

United States • Germany • Japan • Mexico • United Kingdom • China