

**APPLICATIONS:** Concealed doors on entertainment centers, wall units, and cabinets. Use for horizontal or vertical applications with door sizes up to 36" by 24".

Concealed Hinge  
Flipper Door Slide®  
With Optional Detent-Out Feature

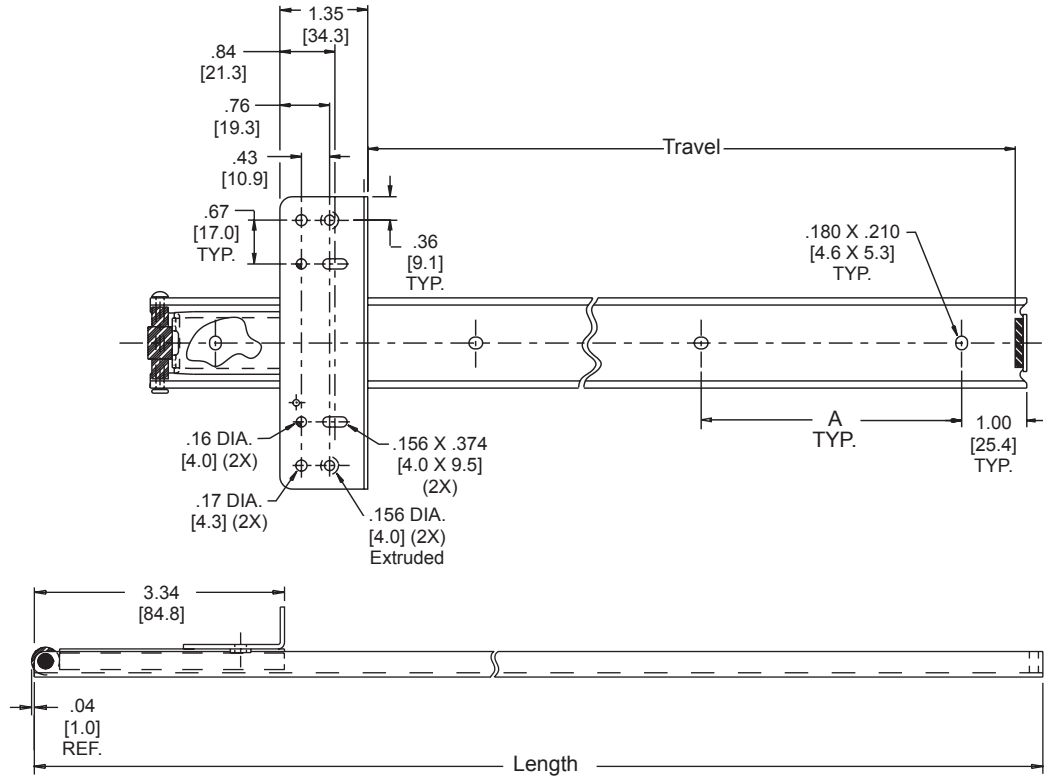
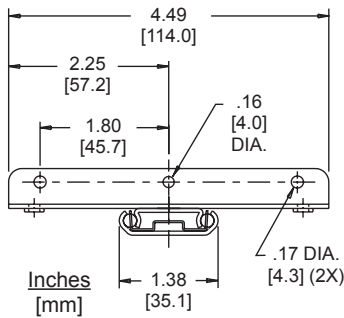
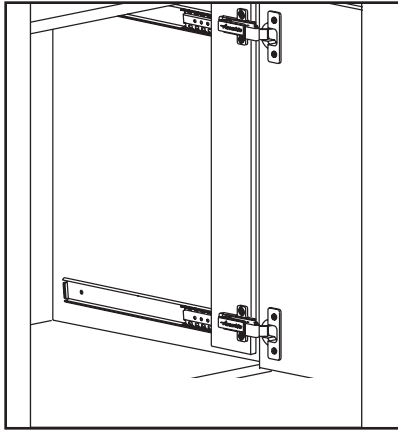

- Finish** Bright electro-zinc (C) or black zinc\* (CB) plating
- Door Sizes** 3/4" [19.0mm] thick **minimum** to 7/8" [22.2mm] thick **maximum**.  
Vertical doors 36" [914.4mm] high by 24" [609.6mm] wide.  
Horizontal doors 36" [914.4mm] wide by 24" [609.6] tall.
- Length** 12" to 28"  
[305mm to 711mm]
- Travel** See Chart
- Load** Up to 25 lbs. [11.4 kg.]
- Also** Optional detent-out feature (ordered as "DO") available. Designed to accept a variety of European hinges.

| Part Number | Length         | Travel         | 'A'             |
|-------------|----------------|----------------|-----------------|
| 117-12      | 12.00<br>[305] | 8.48<br>[215]  | 4.75<br>[120.7] |
| 117-14      | 14.00<br>[356] | 10.48<br>[266] | 5.25<br>[133.4] |
| 117-16      | 16.00<br>[406] | 12.48<br>[317] | 5.25<br>[133.4] |
| 117-18      | 18.00<br>[457] | 14.48<br>[368] | 6.25<br>[158.8] |
| 117-20      | 20.00<br>[508] | 16.48<br>[419] | 6.25<br>[158.8] |
| 117-22      | 22.00<br>[559] | 18.48<br>[469] | 7.25<br>[184.2] |
| 117-24      | 24.00<br>[610] | 20.48<br>[520] | 7.25<br>[184.2] |
| 117-26      | 26.00<br>[660] | 22.48<br>[571] | 7.25<br>[184.2] |
| 117-28      | 28.00<br>[711] | 24.48<br>[622] | 7.25<br>[184.2] |

\*Minimum order quantities may apply.

# Installation Instructions- Vertical Applications Without Partition

## Vertical Application / No Partition

- Step 1. Spend a minute familiarizing yourself with the various terms in the drawings.
- Step 2. Fabricate and rout both ends of a 3/4" follower strip as shown in Figures 1 and 2. Even though a 3/4" follower strip is preferred, it is possible to use one with a minimum thickness of 5/8". Regardless of the size follower strip used, it is necessary to leave 1/2" wood below the rout line when using the Salice hinges recommended on page 3.

**NOTE:** When the use of a 3rd hinge is recommended, another rout located at the midpoint of the follower strip is required. Refer to hinge manufacturer's catalog for number of hinges recommended based on door height.

- Step 3. Attach the follower strip to the slides as shown in Figures 1 and 2. It is essential that a 90° angle exist between the follower strip and the slides. After the follower strip is attached, check to make sure the slides are parallel. If the slides are not parallel, they will not operate properly when installed in the cabinet.

**NOTE:** The follower strip must be attached to the slides prior to the slides being installed in the cabinet.

- Step 4. Mount the hinge mounting plates to the follower strip as shown in Figure 2.

- Step 5. Mount the slides to the cabinet. See Figures 1 and 3. It is essential that both slide rollers be located the same distance from the front of the cabinet. This will ensure the back of the cabinet door will be in contact with the rollers when the door is in the closed position.

- Step 6. Drill the 35mm holes in the door for hinge cups. See Figure 3. Allow the maximum distance between the hinge cup and the edge of the door. The recommended tab distance is specified in the table shown on the page 3.

- Step 7. Install the pivot blocks as shown to prevent premature door rotation. See Figures 3 and 4. The blocks, mounted to the cabinet floor and underside of the top, must contact the back of the door in the open and closed position.

**FINAL STEP:** Adjust door gap as desired, using adjustment features provided by hinge manufacturer.

**CAUTION: CLOSING THE CABINET DOOR EARLY WILL DAMAGE THE DOOR FRONT AND THE SLIDES.**  
The leverage can cause slide separation.

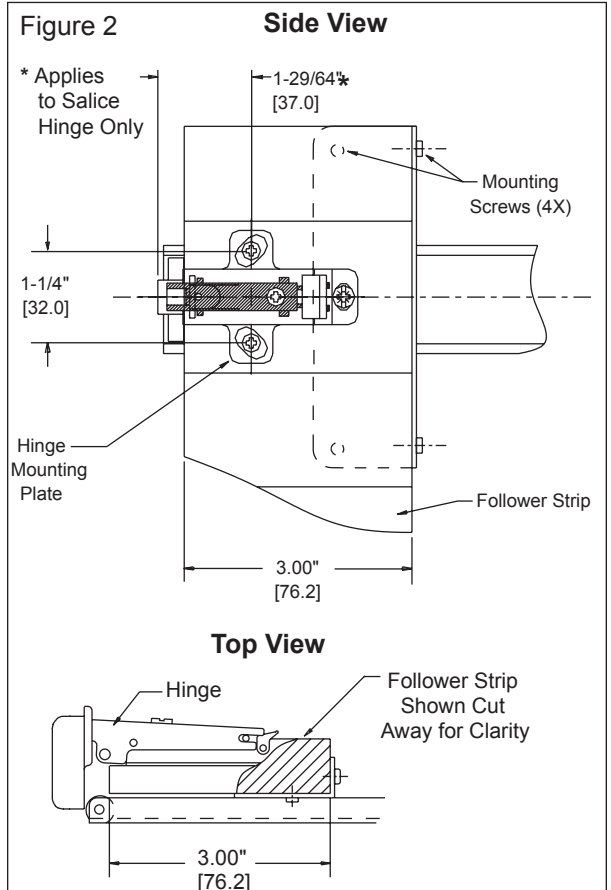
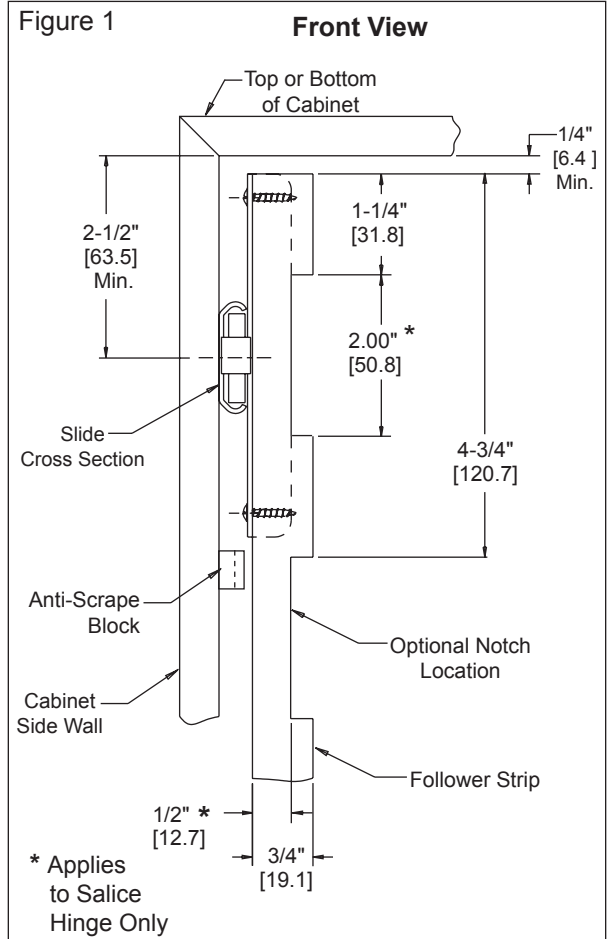

# Installation Instructions

## Vertical Application/With Partition

- Step 1. Allow for an operating envelope as shown in Figure 3. A "pocket" is required to clear door and protruding hinge arms on a 3/4" thick door. See Dimension "A" in Figure 3.
- Step 2. To install and adjust hinge, the front of the partition should be inset approximately 2-1/2" from the back of the closed door.
- Step 3. Continue installation by following Steps 1 through 7 as shown on previous page.

### Pivot Block

For proper door tracking, the pivot block should just touch the back side of the door in both the closed and open positions. See Figure 4. If a partition is being used, set partition in back of block.

### Anti-Scrape Block

To protect the door face and corner, position the anti-scrape block so it is just touching the door back in the closed position. See Figure 5.

**Also:** For tall, heavy doors, consider using Accuride Flipper Door Model 1332/1432 with Anti-Rak Cable System.

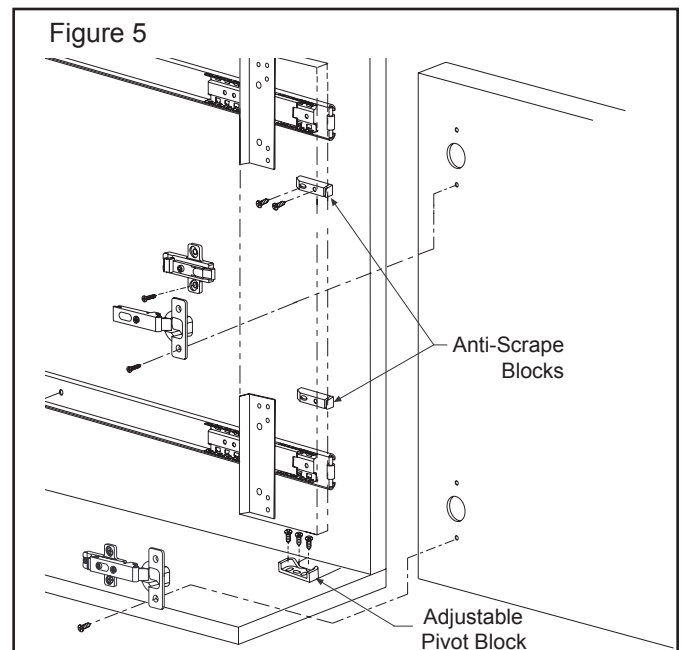
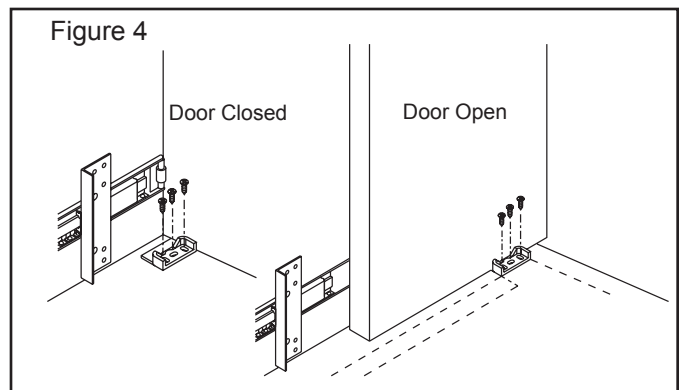
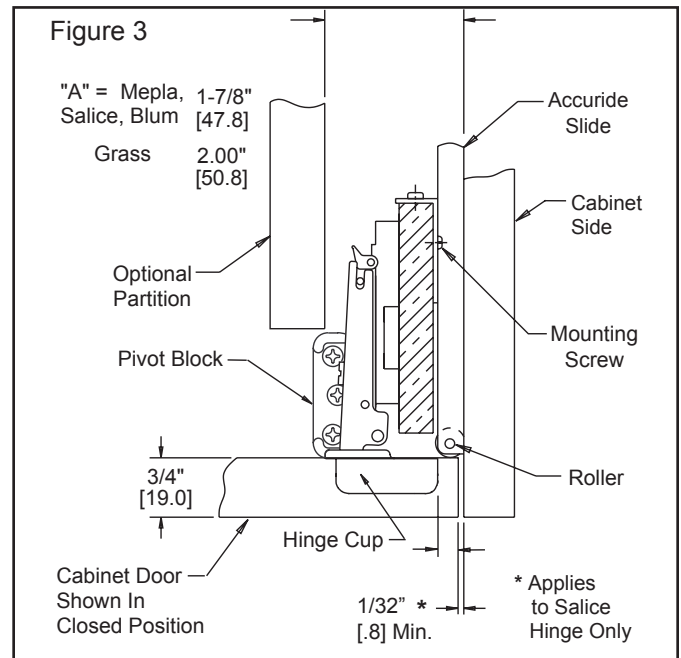

### Recommended Hinges (Vertical Doors)

| MANUFACTURER   | HINGE        | MOUNTING PLATE     | TAB         |
|----------------|--------------|--------------------|-------------|
| Salice Clip-On | C2P7A99      | BAR3P09            | 5/16" [8]   |
| Blum Clip-On   | 71M9550      | 175H7100           | 5/16" [8]   |
| Mepla Clip-On  | DS05-253S-00 | DS7250CN37-00      | 1/4" [6]    |
| Grass Snap-On  | 3606VZ       | G3/RZ1.3/5.2/37 ** | 5/16" [8] * |

\* Requires 3mm notch to the door to clear the hinge arm.

\*\* Base plate set back at 50mm.

## Installation Instructions- Horizontal Applications

For horizontal applications, follow the mounting instructions on Page 2 for Vertical Application/No Partition and rotate the cabinet view 90°. See Figure 6.

- Step 1. Fabricate the follower strip and attach to slides as indicated in Steps 2 & 3 and Figures 1 & 2.
- Step 2. Mount the hinge mounting plates to the follower strip as shown in Figure 2.
- Step 3. Mount the slide to the cabinet ceiling, making sure both slide rollers are located the same distance from the front of the cabinet. This will ensure the back of the cabinet door will be in contact with the rollers when the door is closed.
- Step 4. Follow the instructions for drilling the hinge cup holes in Step 6 of Figure 3.
- Step 5. Install the pivot blocks to the sides of the cabinet wall as shown in Figure 6. The pivot block should just touch the back side of the door in both the open and closed positions.
- Step 6. Position the anti-scrape blocks on cabinet ceiling as shown in Figure 6. The blocks should be placed as close to the slide as possible, without causing interference.

**FINAL STEP:** Adjust door gap as desired, using adjustment features provided by hinge manufacturer.

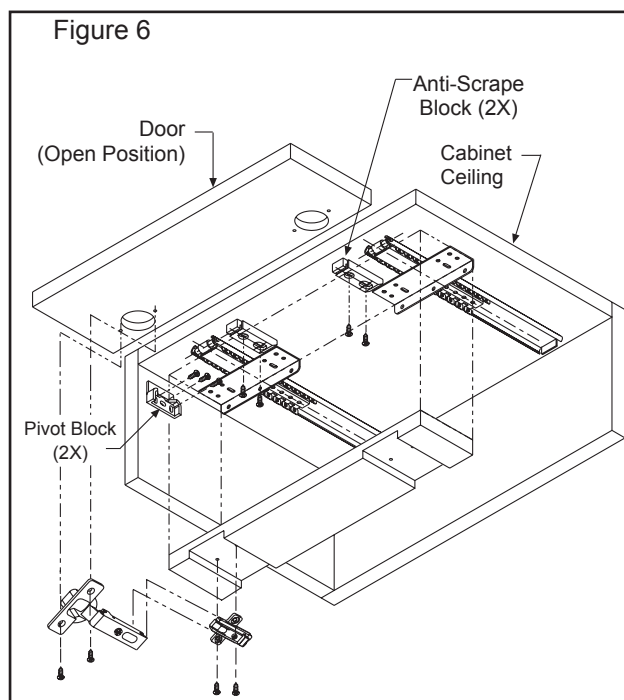

## Specifications

Slide members: Cold rolled steel  
 Ball retainers: Cold rolled steel  
 Ball bearings: Carburized steel

**Note:** Specifications, materials, prices, terms, and delivery are subject to change without notice.

## Slide Ordering Instructions

Complete your order for Accuride Model 117 Flipper Door slide by specifying the following:

|                             |          |       |       |       |       |       |
|-----------------------------|----------|-------|-------|-------|-------|-------|
|                             | 100 Pair | C     | 117   | -18   | -DO   | D     |
| Total Slides Required       | _____    | _____ | _____ | _____ | _____ | _____ |
| Slide Finish                | _____    | _____ | _____ | _____ | _____ | _____ |
| Slide Model                 | _____    | _____ | _____ | _____ | _____ | _____ |
| Slide Length                | _____    | _____ | _____ | _____ | _____ | _____ |
| Optional Detent-Out Feature | _____    | _____ | _____ | _____ | _____ | _____ |
| Optional Polybag Packaging  | _____    | _____ | _____ | _____ | _____ | _____ |

## Packaging

**Distributor (D) Pack:** Polybag contains two slides, one pivot block kit, and mounting screws.

Lengths 12" - 28" 5 pair per box

**Bulk (P) Pack:** Slides only. Pivot block kit ordered separate.

Lengths 12" - 22" 15 pair per box

Lengths 24" - 28" 5 pair per box

## Optional Hardware Kits - Ordered Separately

For optional pivot block kit, order part number 4180-0302-XE. Order one kit per pair of slides. Kit contains:

|        |                           |                  |
|--------|---------------------------|------------------|
| 2 each | Pivot blocks              | P/N 2336-2839-YE |
| 2 each | Anti-scrape blocks        | P/N 2336-2838-YE |
| 6 each | #8 X 7/16" black screws   | P/N 2410-3218-BE |
| 4 each | #8 X 3/4" black screws    | P/N 2410-3205-BE |
| 1 each | Installation instructions |                  |

# Accuride

ACCURIDE INTERNATIONAL INC.

12311 Shoemaker Avenue  
 Santa Fe Springs, CA 90670

TEL (562) 903-0200

FAX (562) 903-0208

www accuride.com

Manufacturing, Engineering, and Sales  
 United States • Germany • Japan • Mexico • United Kingdom